

宁波凯普电子有限公司

Ningbo Keep Improving Electronics Co. Ltd.

Tel:(+86)0574-88370330
Fax:(+86)0574-88370329

E-Mail: kepo@mail.public.nbptt.zj.cn
Http://www.chinaacoustic.com

制 品 规 格 书 Engineering Laboratory Specification

客户名称 Customer		凯普型号 Kepo Model	KPSP3080PN-08/0.25B
客户型号 Customer NO.		图号 DWG NO.	KP3.841.116
概述 Scop.	此确认书仅使用于微型喇叭 This specification is only used for micro speaker		
编号 NO.	项 目 Items	规 格 Specifications	
1	额定功率 Rated Noise Power	0.25W	
2	最大输入功率 Max. Input Power	0.25W	
3	频率范围 Rated Frequency Range	fo ~ 3KHz	
4	谐振频率 Resonant Frequency	500 ± 25% KHz	
5	额定阻抗 Rated Impedance	8	
6	输出声压 Output S. P. L.	72 ± 3dB at 1W/M	
7	壳体材料/颜色 Shell Material/Color	ABS	
8	工作温度 Operating Temperature	-25 ~ +55	
9	贮存温度 Store Temperature	-25 ~ +55	
10	重量 Weight	6.2g	
备 注 Note:			
设计 Designed By	查核 Checked By	承认 Approved By	日期 Date 01.06.26

REVISIONS				APPLICATION	
REV	DESCRIPTION	DATE	APPROVED	NEXT ASSY	USED ON

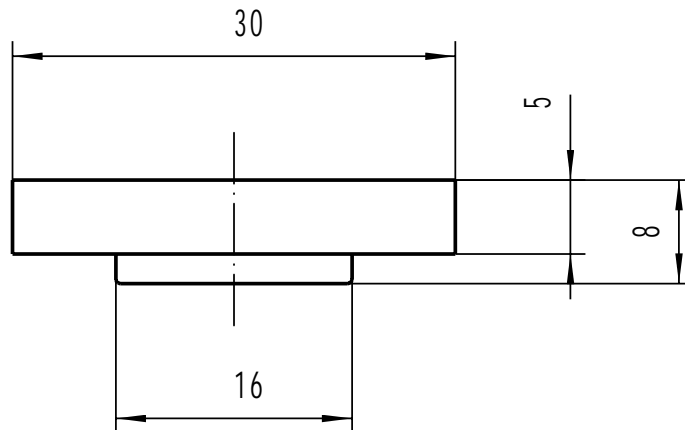
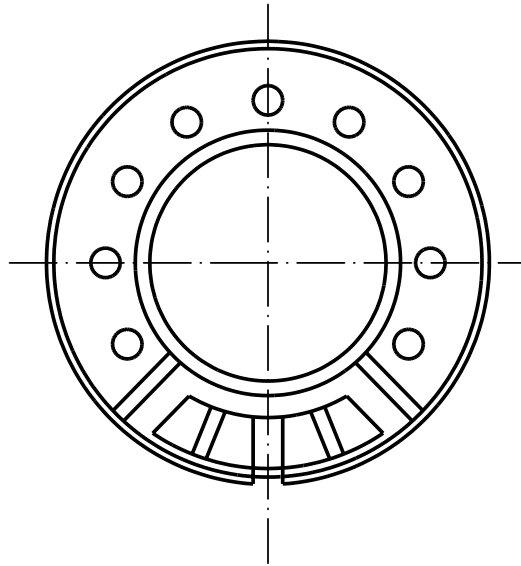

TOLERANCES UNLESS NOTED OTHERWISE .X ± .XX ± .XXX ± 90° FORMED +2° ANGLES -1°		SIGN	DATE	KEPO MODEL NO.	CUSTOMER	
	PREP.		01.06.26	KPSP3080PN-08/0.25B	CUSTOMER NO.	
	ENG.				REV 1.0	SHEET
	PROJ.			DWG NO.	UNIT: mm	SCALE
	CONTRACT NO.			KP3.841.116	KEPO CO.LTD. TEL:(+86)574-88370330 FAX:(+86)574-88370329	
FIRST ANGLE PROJECTION	AGENCY APPROVAL					

